



TOWER

Outillage

Poinçons ronds et matrices - Style 114

Poinçons

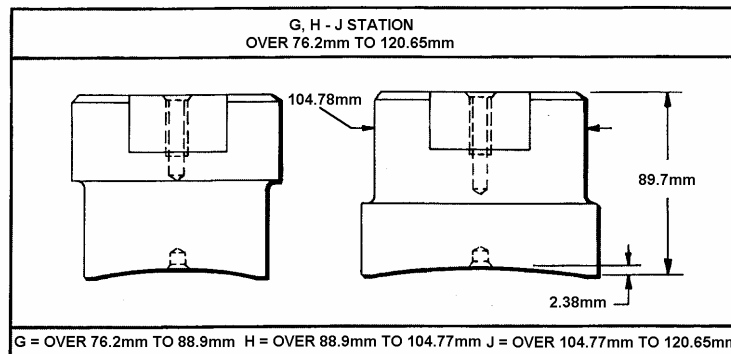
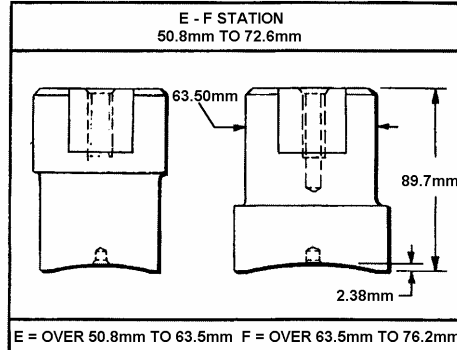
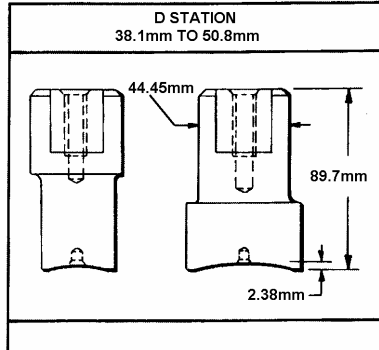
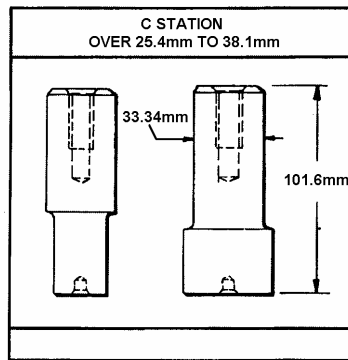
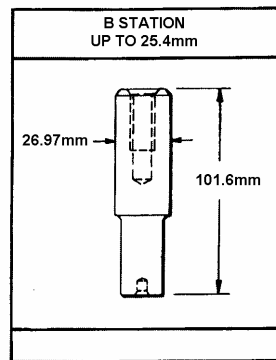

MACHINES – SERVICE – PIÈCES – OUTILLAGE

Tower Machine Tools Limited
 Mayflower Close, Chandlers Ford Industrial Estate, Eastleigh, Hampshire, SO53 4AR
 Phone: +44 (0)23 8026 0266 Fax: +44 (0)23 8026 1012
 E-mail: info@towermachinetools.co.uk
 Web: www.towermachinetools.co.uk



CNC TURRET PUNCH PRESSES



CNC PRESS BRAKES & SHEARS



TOWER

Outillage

Poinçons ronds et matrices - Style 114

Poinçons

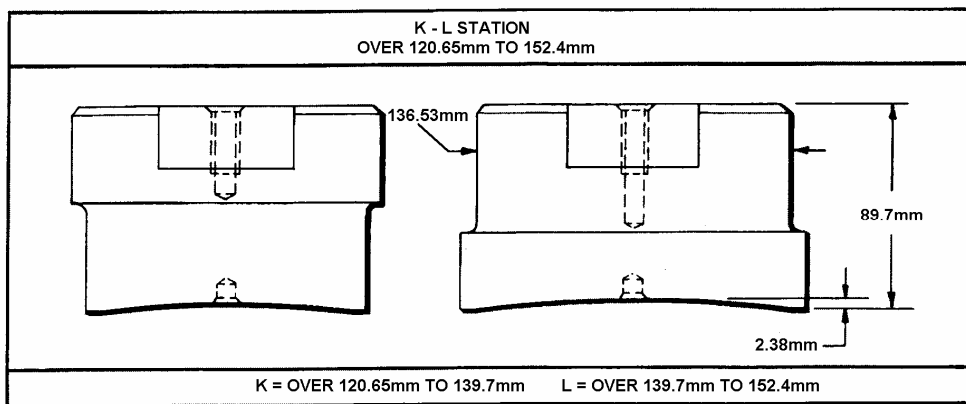

Matrices

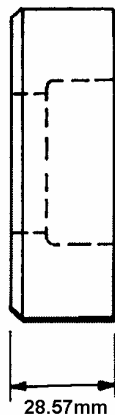
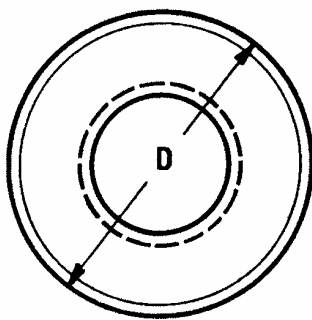

STATION	STATION CAPACITY	D DIM (mm)
B	Up to 25.4mm	39.69
C	Over 25.4 to 38.1mm	57.15
D	Over 38.1 to 50.8mm	69.85
E	Over 50.8 to 63.5mm	88.9
F	Over 63.5 to 76.2mm	101.6
G	Over 76.2 to 88.9mm	114.3
H	Over 88.9 to 104.77mm	133.35
J	Over 104.77 to 120.65mm	152.4
K	Over 120.65 to 139.7mm	177.8
L	Over 139.7 to 152.4mm	190.5

MACHINES – SERVICE – PIECES – OUTILLAGE

Tower Machine Tools Limited
 Mayflower Close, Chandlers Ford Industrial Estate, Eastleigh, Hampshire, SO53 4AR
 Phone: +44 (0)23 8026 0266 Fax: +44 (0)23 8026 1012
 E-mail: info@towermachinetools.co.uk
 Web: www.towermachinetools.co.uk



CNC TURRET PUNCH PRESSES



CNC PRESS BRAKES & SHEARS



TOWER

Outillage

Poinçons et matrices de formes - Style 114

Poinçons

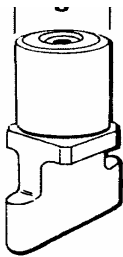

B - C STATIONS
(NO SHEAR)

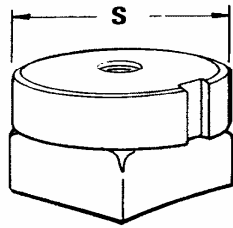



D TO K STATIONS
(SHEAR DEPTH - 2.38mm)

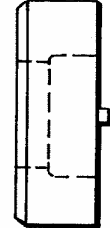
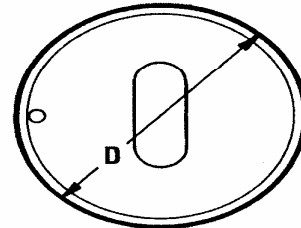



Matrices

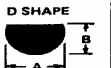
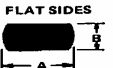

FORMES STANDARD-CARRES. OVALES. RECTANGLE

STATION			
B	Up to 16.0mm	Up to 25.4mm	Up to 22.22mm
C	over 16.0 to 22.22	over 25.4 to 38.1	over 22.22 to 30.93
D	over 22.22 to 31.75	over 38.1 to 50.8	over 30.93 to 44.45
E	over 31.75 to 41.27	over 50.8 to 63.5	over 44.45 to 57.15
F	over 41.27 to 47.62	over 63.5 to 76.2	over 57.15 to 66.67
G	over 47.62 to 57.15	over 76.2 to 88.9	over 66.67 to 79.37
H	over 57.15 to 69.85	over 88.9 to 104.77	over 79.37 to 98.42
J	over 69.85 to 79.37	over 104.77 to 120.65	over 98.42 to 112.7
K	over 79.37 to 92.07	over 120.65 to 139.7	over 112.7 to 130.2
L	over 92.07 to 101.6	over 139.7 to 152.4	over 130.2 to 142.9

QUELQUES FORMES SPECIALES...D'autres formes sont aussi disponibles

STATION						
B	A Dimension = Up to 25.4mm				Up to 22.22mm	Up to 11.11mm
C	A Dimension = over 25.4 to 38.1				over 22.22 to 30.93	over 11.11 to 15.5
D	A Dimension = over 38.1 to 50.8				over 30.93 to 44.45	over 15.5 to 22.3
E	A Dimension = over 50.8 to 63.5				over 44.45 to 57.15	over 22.3 to 28.6
F	A Dimension = over 63.5 to 76.2				over 57.15 to 66.67	over 28.6 to 33.4
G	A Dimension = over 76.2 to 88.9				over 66.67 to 79.37	over 33.4 to 39.7
H	A Dimension = over 88.9 to 104.77				over 79.37 to 98.42	over 39.7 to 49.2
J	A Dimension = over 104.77 to 120.65				over 98.42 to 112.7	over 49.2 to 56.4
K	A Dimension = over 120.65 to 139.7				over 112.7 to 130.2	over 56.4 to 65.1
L	A Dimension = over 139.7 to 152.4				over 130.2 to 142.9	over 65.1 to 71.5

MACHINES – SERVICE – PIECES – OUTILLAGE

Tower Machine Tools Limited

Mayflower Close, Chandlers Ford Industrial Estate, Eastleigh, Hampshire, SO53 4AR

Phone: +44 (0)23 8026 0266 Fax: +44 (0)23 8026 1012

E-mail: info@towermachinetools.co.uk

Web: www.towermachinetools.co.uk



CNC TURRET PUNCH PRESSES



CNC PRESS BRAKES & SHEARS

